











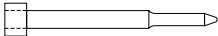
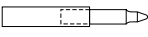

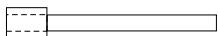
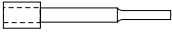

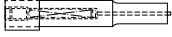

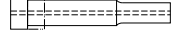
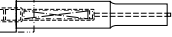
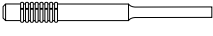

CARBIDE PUNCHES & DIE INSERTS  
PRECISION LINE CATALOG

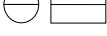

**Oberg Industries**  
PRECISION MANUFACTURING SOLUTIONS

# CONTENTS

Page

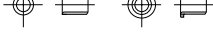
• Carbide Pilots with Machinable Steel Sleeve Head		5
• Carbide Pilots with Steel Pilot Body		5
• Carbide Round Blanks		6
• Carbide Punches, Straight Ground with Machinable Steel Sleeve Head		7
• Carbide Punches with Machinable Steel Sleeve Head		8
• Carbide Punches with Air Hole and Machinable Steel Sleeve Head		9
• Carbide Punches with Self-Contained Ejector Pin and Machinable Steel Sleeve Head		10
• Carbide Punches with Carbide Head and Hardened Steel Collar		11
• Carbide Punches with Air Hole, Carbide Head and Hardened Steel Collar		12
• Carbide Punches with Self-Contained Ejector Pin, Carbide Head and Hardened Steel Collar		13
• Carbide Step-A-Head® Punches		14
• Carbide Punches, Ball Retainer Type - Light Duty		15
• Carbide Die Inserts with Full Length Taper		16
• Carbide Die Inserts with Full Length Taper and Machinable Steel Sleeve Head		17
• Carbide Die Inserts with Counterbore		18
• Carbide Die Inserts with Counterbore		19
• Carbide Die Inserts with Counterbore and Machinable Steel Sleeve Head		20
• Carbide Die Inserts with Counterbore and Machinable Steel Sleeve Head		21
• Carbide Die Inserts, Half Rounds		22
• Carbide Die Inserts, Wire EDM Blanks With Starter Hole		23
• Carbide Drill Jig Bushings Slip Renewable Type "CSR"		24
• Carbide Drill Jig Bushings Fixed Renewable Type "CFR"		25
• Carbide Drill Jig Bushings Press Fit Type "CP" and "CH"		26
• Special Shapes		27
• Locating Devices		28



# Oberg Industries

# Oberg Slug Retention

## *Reduce Excessive Manufacturing Costs Associated With Slug Pulling In Your Stamping Operations*

Downtime, broken die components and rejected parts can be extremely costly. Oberg's Slug Retention process can solve those nagging problems by reducing the risk of slugs being pulled to the die surface during withdrawal of the punch.



Slug Retention can be used on carbide bushings or die sections with counterbore, tapered or straight I.D. styles, in rounds and most shapes.



### **Our Method Is User Friendly**

Because our process is based on your application, no redesigning of your current tooling is required. This process is very dependable and can be

precisely duplicated each time a component needs to be replaced.

### **Performance Is Guaranteed**

Our Slug Retention method will totally eliminate or greatly reduce your slug pulling difficulties. Test our proven system and receive this guarantee: **Use Oberg Slug Retention and if you are not completely satisfied, we will refund the full cost of the Slug Retention alteration. (This guarantee is limited to only round shapes with inside diameters greater than 0.040").**

### **What It Does**

Oberg Slug Retention is a solution for controlling slugs in carbide die bushings or die sections. This process places an exact amount of trap on the slug to maintain a smooth, even flow of slugs away from the working area of the die. Slug Retention is user friendly and requires no redesigning of your tooling and no special drawings.

### **How It Works**

With our Slug Retention method, a series of carefully calculated interference points are produced on the slug that help to eliminate slug pulling. A precise amount of interference is applied to the blanked slug so that vacuum forces will not pull it back into the work area. The slug expands into a series of special grooves manufactured in the die bushing or die section effectively retaining the slug. These grooves are engineered to prevent the slug from pulling back onto the die face where damage can occur.

### **Features & Benefits**

Eliminates or reduces the following:

- Punch breakage due to double hits
- Use of ejector punches or air holes
- Slug marks on parts
- Press downtime
- Wasted material
- Die maintenance
- New die development

### **How to Order**

Just send us your print via mail, fax or e-mail and include the following information:

- Material type
- Material thickness
- Material hardness
- Break clearance per side

## Carbide Punches with Machinable Steel Sleeve Type Head

These punches are recommended for medium to heavy punching requirements. They will out-perform steel punches many times, and they perform best when used in good quality dies.

The length of the steel sleeve (head thickness "T") is standard at 1/2", but may be ordered at any specified dimension.

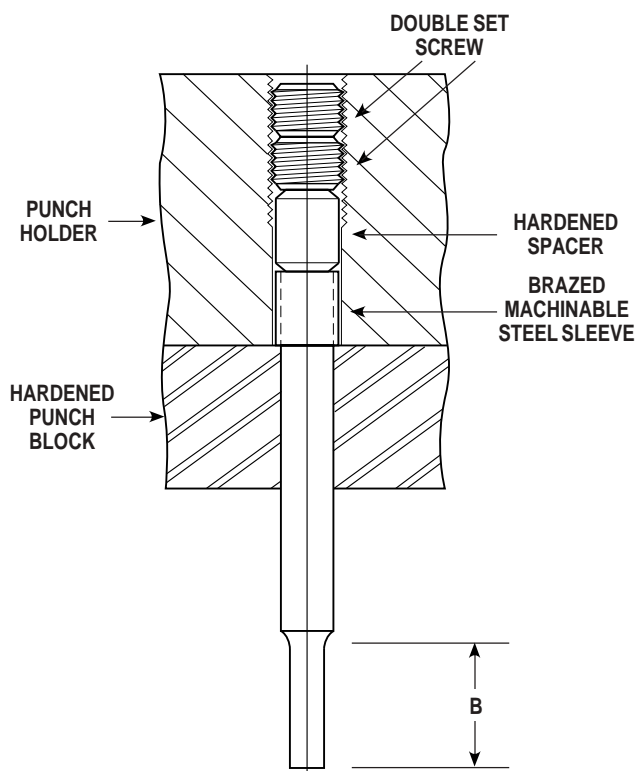

In the sectional view above, please note that:

1. Double set screws are recommended.
2. The hardened spacer next to the punch head is optional, and may be omitted.
3. By turning or grinding the shoulder of the soft steel head, the effective body length of the punch may be increased.
4. In most sizes, the length of the punch tip "B" may be renewed or increased by sending to OCP&D for regrinding, or by regrinding in your own shop.

## Carbide Punches with Carbide Head and Hardened Steel Collar

These punches are for the stamper who prefers one piece carbide punches with carbide heads. They will out-perform steel punches many times when used in good quality dies.

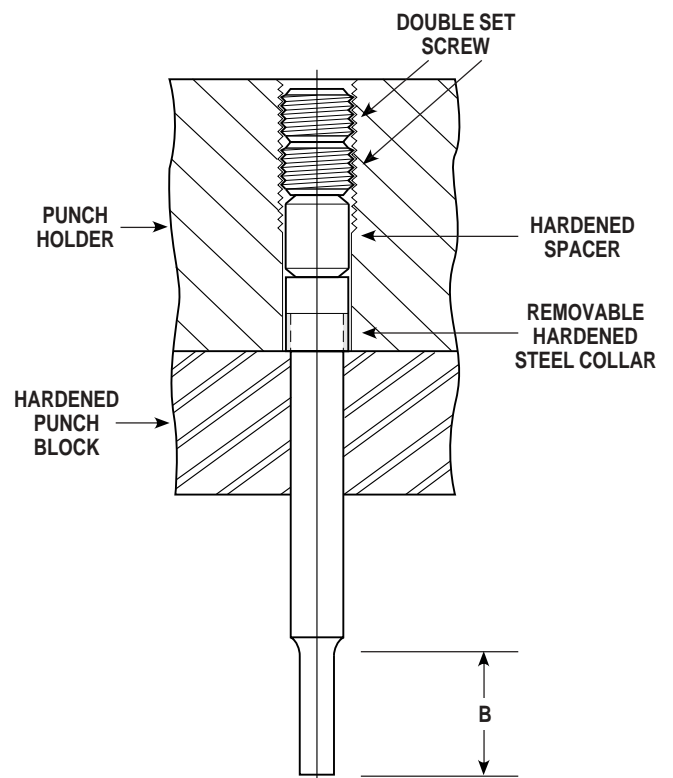

In the sectional view above, please note that:

1. Double set screws are recommended.
2. The hardened spacer is optional, and may be omitted.
3. To facilitate adjustment, each punch is supplied with a hardened steel collar which may be removed and ground off.
4. In most sizes, the length of the punch tip "B" may be renewed or increased by sending to OCP&D for regrinding, or by regrinding in your own shop.

# Carbide Pilots with Machinable Steel Sleeve Head

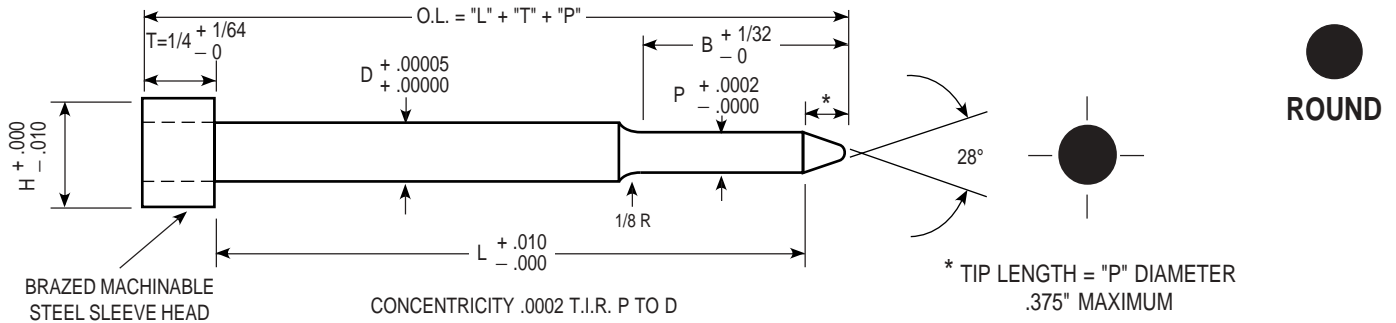

CATALOG NUMBER	D BODY DIAMETER	P POINT DIAMETER	B POINT LENGTH	H HEAD DIAMETER	L = LENGTH UNDER HEAD						
					2	2 1/4	2 1/2	2 3/4	3	3 1/4	3 1/2
2PNS-18	.1875	.061 - .1875	3/4"	.296	•	•	•	•	•	•	•
1PNS-25	.250	.060 - .1259	3/4"	.340	•	•	•	•	•	•	•
2PNS-25	.250	.126 - .250	1"	.340	•	•	•	•	•	•	•
1PNS-31	.3125	.125 - .2499	1"	.400	•	•	•	•	•	•	•
2PNS-31	.3125	.250 - .3125	1"	.400	•	•	•	•	•	•	•
1PNS-37	.375	.187 - .3139	1"	.460	•	•	•	•	•	•	•
2PNS-37	.375	.314 - .375	1"	.460	•	•	•	•	•	•	•
1PNS-43	.4375	.314 - .3749	1"	.562	•	•	•	•	•	•	•
2PNS-43	.4375	.375 - .4375	1"	.562	•	•	•	•	•	•	•
1PNS-50	.500	.375 - .4379	1"	.625	•	•	•	•	•	•	•
2PNS-50	.500	.438 - .500	1"	.625	•	•	•	•	•	•	•
1PNS-62	.625	.438 - .5299	1"	.750	•	•	•	•	•	•	•
2PNS-62	.625	.530 - .625	1"	.750	•	•	•	•	•	•	•
1PNS-75	.750	.530 - .6299	1"	.875	•	•	•	•	•	•	•
2PNS-75	.750	.630 - .750	1"	.875	•	•	•	•	•	•	•



WHEN ORDERING SPECIFY:

Quantity	Catalog Number	L	P
7	1PNS-37	3"	.2200"

NOTE: ANY DIMENSION OTHER THAN THOSE SHOWN QUOTED ON REQUEST

# Carbide Pilots with Steel Pilot Body

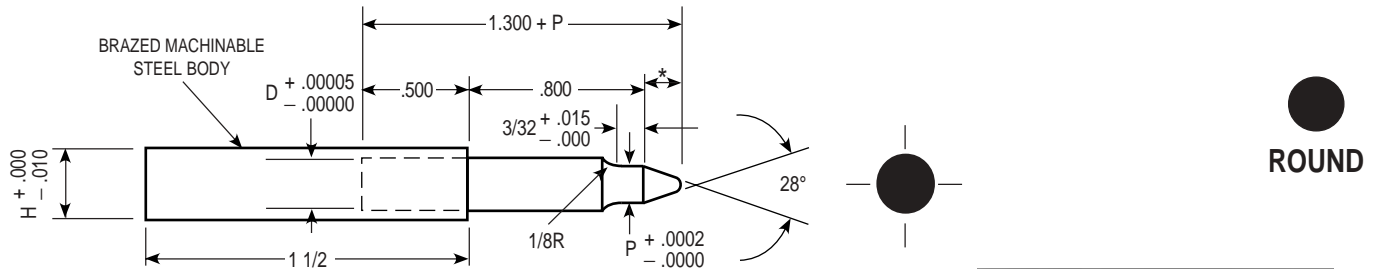

CATALOG NUMBER	H STEEL BODY DIAMETER	D CARBIDE DIAMETER	P POINT DIAMETER
1PNSP-18	.296	.1875	.061 - .1875
1PNSP-25	.340	.250	.061 - .250
1PNSP-31	.400	.3125	.125 - .3125
1PNSP-37	.460	.375	.187 - .375

\* TIP LENGTH = "P" DIAMETER .375" MAXIMUM

WHEN ORDERING SPECIFY:

Quantity	Catalog Number	P
6	1PNSP-31	.2500



# Carbide Round Blanks Precision Ground

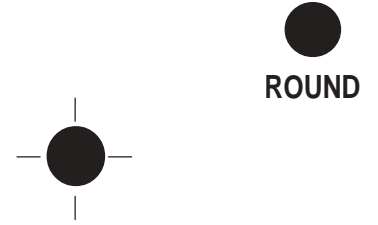
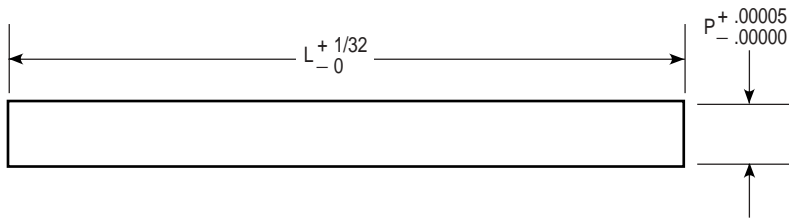

CATALOG NUMBER	P POINT DIAMETER	L = LENGTH										
		1½	1¾	2	2¼	2½	2¾	3	3¼	3½	3¾	4
1PR	.0625	•	•	•	•	•	•	•	•	•	•	•
2PR	.125	•	•	•	•	•	•	•	•	•	•	•
3PR	.1875	•	•	•	•	•	•	•	•	•	•	•
4PR	.250	•	•	•	•	•	•	•	•	•	•	•
5PR	.3125	•	•	•	•	•	•	•	•	•	•	•
6PR	.375	•	•	•	•	•	•	•	•	•	•	•
7PR	.4375	•	•	•	•	•	•	•	•	•	•	•
8PR	.500	•	•	•	•	•	•	•	•	•	•	•
9PR	.625	•	•	•	•	•	•	•	•	•	•	•
10PR	.750	•	•	•	•	•	•	•	•	•	•	•



NOTE: ANY DIMENSION OTHER THAN THOSE SHOWN QUOTED ON REQUEST

WHEN ORDERING SPECIFY:

Quantity	Catalog Number	L
12	8PR	2½"

# Carbide Round Blanks Precision Ground

CATALOG NUMBER	P +.0002 - .0000 DIAMETER	L = LENGTH + 1/32 - 0
SCR	.005" - .029"	AVAILABLE IN LENGTHS UP TO 6"

CATALOG NUMBER	P +.00005 - .000 DIAMETER	L = LENGTH + 1/32 - 0
SCR	.030" - .375"	AVAILABLE IN LENGTHS UP TO 6"

NOTE: ANY DIMENSION OTHER THAN THOSE SHOWN QUOTED ON REQUEST

WHEN ORDERING SPECIFY:

Quantity	Catalog Number	L	P
10	SCR	¾"	.1212"

# Carbide Punches, Straight Ground with Machinable Steel Sleeve Head

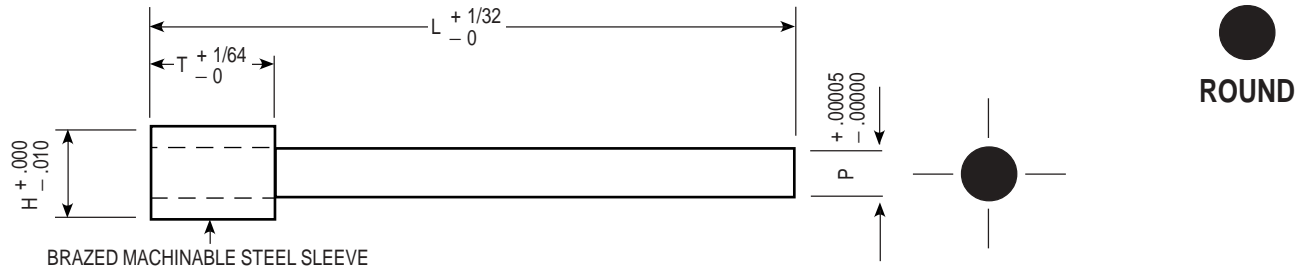

CATALOG NUMBER	P POINT DIAMETER	H HEAD DIAMETER	T HEAD LENGTH	L = LENGTH											
				1½	1¾	2	2¼	2½	2¾	3	3¼	3½	3¾	4	
1PQ	.045 - .0649	.125	3/16"	•	•	•	•	•	•	•	•	•	•	•	
2PQ	.065 - .0879	.125	3/16"	•	•	•	•	•	•	•	•	•	•	•	
3PQ	.088 - .1249	.171	3/16"	•	•	•	•	•	•	•	•	•	•	•	
3PQA	.125	.171	3/16"	•	•	•	•	•	•	•	•	•	•	•	
4PQ	.1251 - .1409	.203	1/4"	•	•	•	•	•	•	•	•	•	•	•	
5PQ	.141 - .1569	.218	1/4"	•	•	•	•	•	•	•	•	•	•	•	
6PQ	.157 - .1729	.234	1/4"	•	•	•	•	•	•	•	•	•	•	•	
7PQ	.173 - .1874	.250	1/4"	•	•	•	•	•	•	•	•	•	•	•	
8PQ	.1875	.296	1/2"	•	•	•	•	•	•	•	•	•	•	•	
9PQ	.1876 - .2049	.296	1/2"	•	•	•	•	•	•	•	•	•	•	•	
10PQ	.205 - .2199	.340	1/2"	•	•	•	•	•	•	•	•	•	•	•	
11PQ	.220 - .2359	.340	1/2"	•	•	•	•	•	•	•	•	•	•	•	
12PQ	.236 - .2499	.340	1/2"	•	•	•	•	•	•	•	•	•	•	•	
13PQ	.250	.340	1/2"	•	•	•	•	•	•	•	•	•	•	•	
14PQ	.2501 - .2669	.400	1/2"	•	•	•	•	•	•	•	•	•	•	•	
15PQ	.267 - .2829	.400	1/2"	•	•	•	•	•	•	•	•	•	•	•	
16PQ	.283 - .2979	.400	1/2"	•	•	•	•	•	•	•	•	•	•	•	
17PQ	.298 - .3124	.400	1/2"	•	•	•	•	•	•	•	•	•	•	•	
18PQ	.3125	.400	1/2"	•	•	•	•	•	•	•	•	•	•	•	
19PQ	.3126 - .3439	.460	1/2"	•	•	•	•	•	•	•	•	•	•	•	
20PQ	.344 - .3749	.460	1/2"	•	•	•	•	•	•	•	•	•	•	•	
21PQ	.375	.460	1/2"	•	•	•	•	•	•	•	•	•	•	•	
1PQ-43	.4375	.562	1/2"	•	•	•	•	•	•	•	•	•	•	•	
1PQ-50	.500	.625	1/2"	•	•	•	•	•	•	•	•	•	•	•	
1PQ-62	.625	.750	1/2"	•	•	•	•	•	•	•	•	•	•	•	
1PQ-75	.750	.875	1/2"	•	•	•	•	•	•	•	•	•	•	•	

NOTE: ANY DIMENSION OTHER THAN THOSE SHOWN QUOTED ON REQUEST



### WHEN ORDERING SPECIFY:

Quantity	Catalog Number	L	P
3	12PQ	3"	.2420"

# Carbide Punches with Machinable Steel Sleeve Head

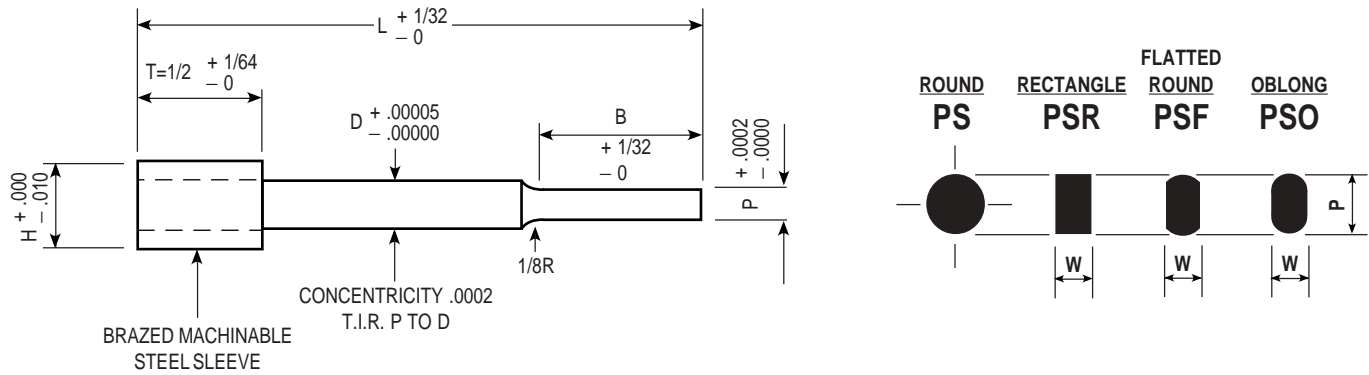

CATALOG NUMBER	D BODY DIAMETER	P POINT DIAMETER	B POINT LENGTH	H HEAD DIAMETER	L = LENGTH									
					2	2¼	2½	2¾	3	3¼	3½	3¾	4	
1PS-12	.125	.031 - .0609	5/16"	.171	•	•	•	•	•	•	•	•	•	•
2PS-12	.125	.061 - .125	3/4"	.171	•	•	•	•	•	•	•	•	•	•
1PS-18	.1875	.031 - .0609	5/16"	.296	•	•	•	•	•	•	•	•	•	•
2PS-18	.1875	.061 - .1875	3/4"	.296	•	•	•	•	•	•	•	•	•	•
1PS-25	.250	.060 - .1259	3/4"	.340	•	•	•	•	•	•	•	•	•	•
2PS-25	.250	.126 - .250	7/8"	.340	•	•	•	•	•	•	•	•	•	•
1PS-31	.3125	.125 - .2499	7/8"	.400	•	•	•	•	•	•	•	•	•	•
2PS-31	.3125	.250 - .3125	7/8"	.400	•	•	•	•	•	•	•	•	•	•
1PS-37	.375	.187 - .3139	7/8"	.460	•	•	•	•	•	•	•	•	•	•
2PS-37	.375	.314 - .375	7/8"	.460	•	•	•	•	•	•	•	•	•	•
1PS-43	.4375	.314 - .3749	7/8"	.562	•	•	•	•	•	•	•	•	•	•
2PS-43	.4375	.375 - .4375	7/8"	.562	•	•	•	•	•	•	•	•	•	•
1PS-50	.500	.375 - .4379	7/8"	.625	•	•	•	•	•	•	•	•	•	•
2PS-50	.500	.438 - .500	7/8"	.625	•	•	•	•	•	•	•	•	•	•
1PS-62	.625	.438 - .5299	7/8"	.750	•	•	•	•	•	•	•	•	•	•
2PS-62	.625	.530 - .625	7/8"	.750	•	•	•	•	•	•	•	•	•	•
1PS-75	.750	.530 - .6299	7/8"	.875	•	•	•	•	•	•	•	•	•	•
2PS-75	.750	.630 - .750	7/8"	.875	•	•	•	•	•	•	•	•	•	•

NOTE: ANY DIMENSION OTHER THAN THOSE SHOWN QUOTED ON REQUEST

All outside corners to be sharp unless otherwise specified by customer.

**WHEN ORDERING SPECIFY:**

Quantity	Catalog Number	L	P
5	2PS-43	3½"	.4000"

Quantity	Catalog Number	L	Point Dimensions
12	1PSF-18	2½"	W = .1320" P = .1875"



# Carbide Punches with Air Hole and Machinable Steel Sleeve Head

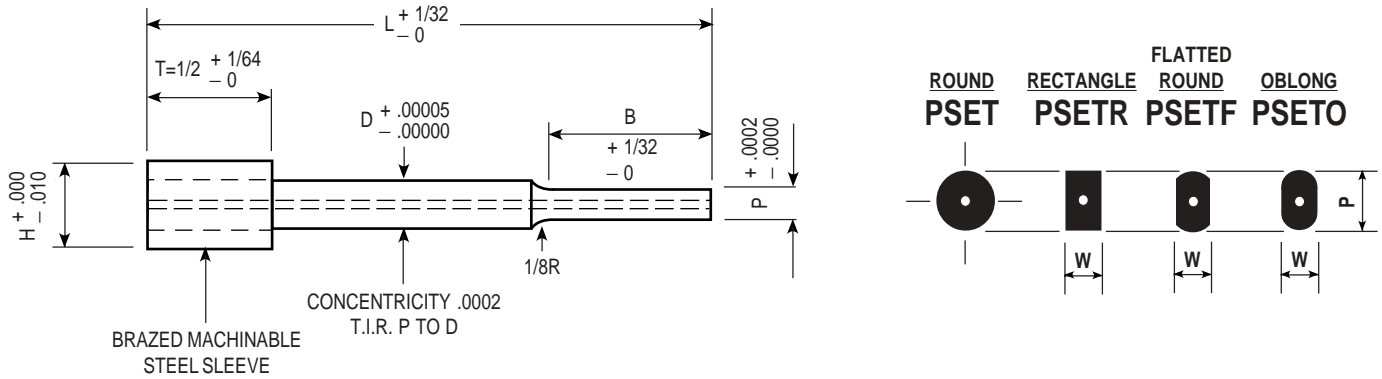

CATALOG NUMBER	D DIAMETER	P POINT DIAMETER	B POINT LENGTH	H HEAD DIAMETER	AIR HOLE DIA.	L = LENGTH								
						2	2¼	2½	2¾	3	3¼	3½	3¾	4
1PSET-18	.1875	.093 - .1259	3/4"	.296	3/64"	•	•	•	•	•	•	•	•	•
2PSET-18	.1875	.126 - .1875	7/8"	.296	3/64"	•	•	•	•	•	•	•	•	•
1PSET-25	.250	.093 - .1259	3/4"	.340	3/64"	•	•	•	•	•	•	•	•	•
2PSET-25	.250	.126 - .250	7/8"	.340	3/64"	•	•	•	•	•	•	•	•	•
1PSET-31	.3125	.125 - .2499	7/8"	.400	3/64"	•	•	•	•	•	•	•	•	•
2PSET-31	.3125	.250 - .3125	7/8"	.400	3/64"	•	•	•	•	•	•	•	•	•
1PSET-37	.375	.187 - .3139	7/8"	.460	5/64"	•	•	•	•	•	•	•	•	•
2PSET-37	.375	.314 - .375	7/8"	.460	5/64"	•	•	•	•	•	•	•	•	•
1PSET-43	.4375	.314 - .3749	7/8"	.562	7/64"	•	•	•	•	•	•	•	•	•
2PSET-43	.4375	.375 - .4375	7/8"	.562	7/64"	•	•	•	•	•	•	•	•	•
1PSET-50	.500	.375 - .4379	7/8"	.625	9/64"	•	•	•	•	•	•	•	•	•
2PSET-50	.500	.438 - .500	7/8"	.625	9/64"	•	•	•	•	•	•	•	•	•
1PSET-62	.625	.438 - .5299	7/8"	.750	9/64"	•	•	•	•	•	•	•	•	•
2PSET-62	.625	.530 - .625	7/8"	.750	9/64"	•	•	•	•	•	•	•	•	•

NOTE: ANY DIMENSION OTHER THAN THOSE SHOWN QUOTED ON REQUEST

All outside corners to be sharp unless otherwise specified by customer.

### WHEN ORDERING SPECIFY:

Quantity	Catalog Number	L	P
3	1PSET-50	3"	.4120"

Quantity	Catalog Number	L	Point Dimensions
12	1PSETO-18	2"	W = .1270" P = .1800"



# Carbide Punches with Self-Contained Ejector Pin and Machinable Steel Sleeve Head

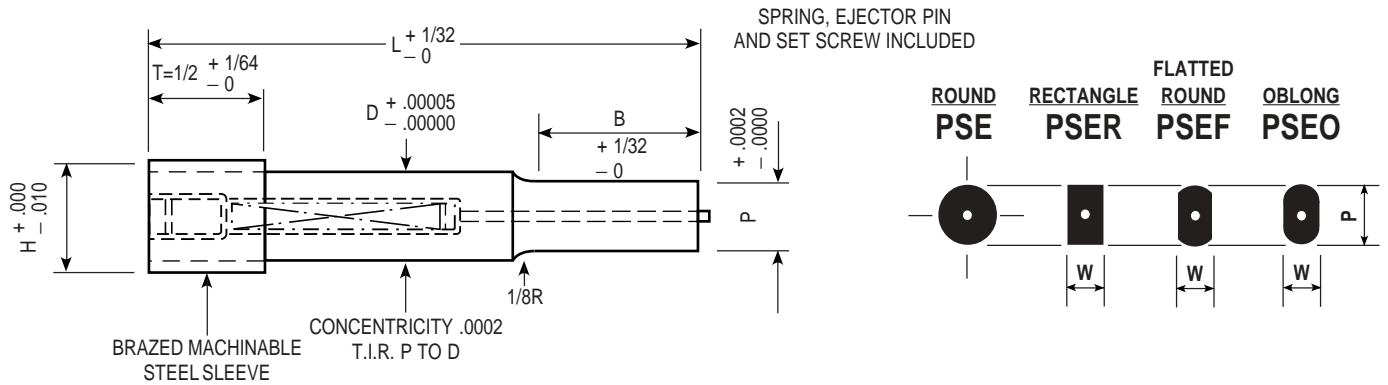

CATALOG NUMBER	D DIAMETER	P POINT DIAMETER	B POINT LENGTH	H HEAD DIAMETER	L = LENGTH									
					2	2¼	2½	2¾	3	3¼	3½	3¾	4	
1PSE-18	.1875	.093 - .1259	3/4"	.296	•	•	•	•	•	•	•	•	•	•
2PSE-18	.1875	.126 - .1875	7/8"	.296	•	•	•	•	•	•	•	•	•	•
1PSE-25	.250	.093 - .1259	3/4"	.340	•	•	•	•	•	•	•	•	•	•
2PSE-25	.250	.126 - .250	7/8"	.340	•	•	•	•	•	•	•	•	•	•
1PSE-31	.3125	.125 - .2499	7/8"	.400	•	•	•	•	•	•	•	•	•	•
2PSE-31	.3125	.250 - .3125	7/8"	.400	•	•	•	•	•	•	•	•	•	•
1PSE-37	.375	.187 - .3139	7/8"	.460	•	•	•	•	•	•	•	•	•	•
2PSE-37	.375	.314 - .375	7/8"	.460	•	•	•	•	•	•	•	•	•	•
1PSE-43	.4375	.314 - .3749	7/8"	.562	•	•	•	•	•	•	•	•	•	•
2PSE-43	.4375	.375 - .4375	7/8"	.562	•	•	•	•	•	•	•	•	•	•
1PSE-50	.500	.375 - .4379	7/8"	.625	•	•	•	•	•	•	•	•	•	•
2PSE-50	.500	.438 - .500	7/8"	.625	•	•	•	•	•	•	•	•	•	•
1PSE-62	.625	.438 - .5299	7/8"	.750	•	•	•	•	•	•	•	•	•	•
2PSE-62	.625	.530 - .625	7/8"	.750	•	•	•	•	•	•	•	•	•	•

NOTE: ANY DIMENSION OTHER THAN THOSE SHOWN QUOTED ON REQUEST

All outside corners to be sharp unless otherwise specified by customer.

**WHEN ORDERING SPECIFY:**

Quantity	Catalog Number	L	P
3	2PSE-43	3½"	.4020"

Quantity	Catalog Number	L	Point Dimensions
12	1PSE-50	3½"	W = .2500" P = .3750"



# Carbide Punches with Carbide Head and Hardened Steel Collar

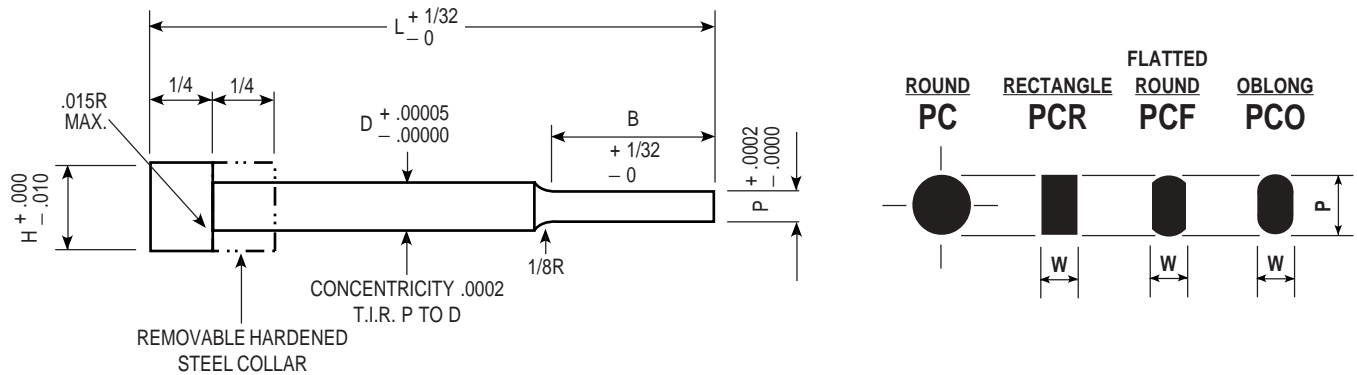

CATALOG NUMBER	D BODY DIAMETER	P POINT DIAMETER	B POINT LENGTH	H HEAD DIAMETER	L = LENGTH									
					2	2¼	2½	2¾	3	3¼	3½	3¾	4	
1PC-18	.1875	.031 - .0609	5/16"	.296	•	•	•	•	•	•	•	•	•	•
2PC-18	.1875	.061 - .1875	3/4"	.296	•	•	•	•	•	•	•	•	•	•
1PC-25	.250	.060 - .1259	3/4"	.340	•	•	•	•	•	•	•	•	•	•
2PC-25	.250	.126 - .250	7/8"	.340	•	•	•	•	•	•	•	•	•	•
1PC-31	.3125	.125 - .2499	7/8"	.400	•	•	•	•	•	•	•	•	•	•
2PC-31	.3125	.250 - .3125	7/8"	.400	•	•	•	•	•	•	•	•	•	•
1PC-37	.375	.187 - .3139	7/8"	.460	•	•	•	•	•	•	•	•	•	•
2PC-37	.375	.314 - .375	7/8"	.460	•	•	•	•	•	•	•	•	•	•
1PC-43	.4375	.314 - .3749	7/8"	.562	•	•	•	•	•	•	•	•	•	•
2PC-43	.4375	.375 - .4375	7/8"	.562	•	•	•	•	•	•	•	•	•	•
1PC-50	.500	.375 - .4379	7/8"	.625	•	•	•	•	•	•	•	•	•	•
2PC-50	.500	.438 - .500	7/8"	.625	•	•	•	•	•	•	•	•	•	•
1PC-62	.625	.438 - .5299	7/8"	.750	•	•	•	•	•	•	•	•	•	•
2PC-62	.625	.530 - .625	7/8"	.750	•	•	•	•	•	•	•	•	•	•
1PC-75	.750	.530 - .6299	7/8"	.875	•	•	•	•	•	•	•	•	•	•
2PC-75	.750	.630 - .750	7/8"	.875	•	•	•	•	•	•	•	•	•	•

NOTE: ANY DIMENSION OTHER THAN THOSE SHOWN QUOTED ON REQUEST

All outside corners to be sharp unless otherwise specified by customer.

## WHEN ORDERING SPECIFY:

Quantity	Catalog Number	L	P
3	1PC-31	3"	.1260"

Quantity	Catalog Number	L	Point Dimensions
12	1PCF-25	3½"	W = .1775" P = .2250"



# Carbide Punches with Air Hole, Carbide Head and Hardened Steel Collar

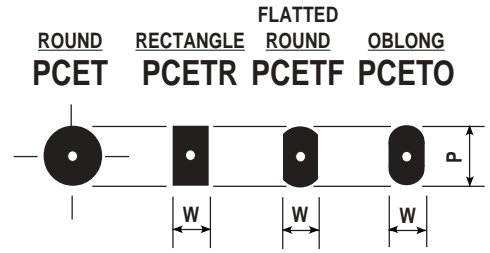
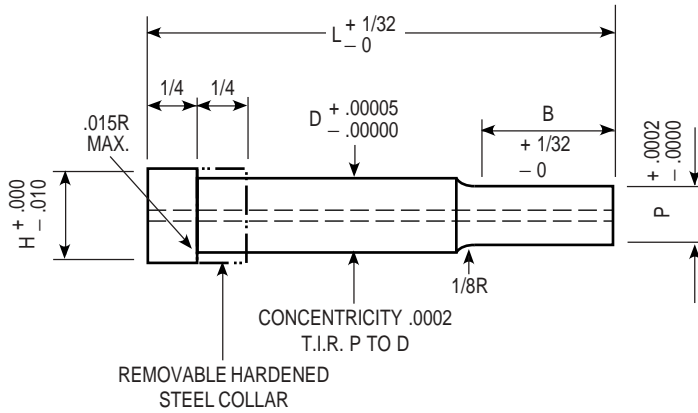

CATALOG NUMBER	D DIAMETER	P POINT DIAMETER	B POINT LENGTH	H HEAD DIAMETER	AIR HOLE DIA.	L = LENGTH								
						2	2¼	2½	2¾	3	3¼	3½	3¾	4
1PCET-18	.1875	.093 - .1259	3/4"	.296	3/64"	•	•	•	•	•	•	•	•	•
2PCET-18	.1875	.126 - .1875	7/8"	.296	3/64"	•	•	•	•	•	•	•	•	•
1PCET-25	.250	.093 - .1259	3/4"	.340	3/64"	•	•	•	•	•	•	•	•	•
2PCET-25	.250	.126 - .250	7/8"	.340	3/64"	•	•	•	•	•	•	•	•	•
1PCET-31	.3125	.125 - .2499	7/8"	.400	3/64"	•	•	•	•	•	•	•	•	•
2PCET-31	.3125	.250 - .3125	7/8"	.400	3/64"	•	•	•	•	•	•	•	•	•
1PCET-37	.375	.187 - .3139	7/8"	.460	5/64"	•	•	•	•	•	•	•	•	•
2PCET-37	.375	.314 - .375	7/8"	.460	5/64"	•	•	•	•	•	•	•	•	•
1PCET-43	.4375	.314 - .3749	7/8"	.562	7/64"	•	•	•	•	•	•	•	•	•
2PCET-43	.4375	.375 - .4375	7/8"	.562	7/64"	•	•	•	•	•	•	•	•	•
1PCET-50	.500	.375 - .4379	7/8"	.625	9/64"	•	•	•	•	•	•	•	•	•
2PCET-50	.500	.438 - .500	7/8"	.625	9/64"	•	•	•	•	•	•	•	•	•
1PCET-62	.625	.500 - .5749	7/8"	.750	9/64"	•	•	•	•	•	•	•	•	•
2PCET-62	.625	.575 - .625	7/8"	.750	9/64"	•	•	•	•	•	•	•	•	•

NOTE: ANY DIMENSION OTHER THAN THOSE SHOWN QUOTED ON REQUEST

All outside corners to be sharp unless otherwise specified by customer.

## WHEN ORDERING SPECIFY:

Quantity	Catalog Number	L	P
3	1PCET-25	3"	.1000"

Quantity	Catalog Number	L	Point Dimensions
12	1PCETR-31	3"	W = .1875" P = .2500"



# Carbide Punches with Self-Contained Ejector Pin, Carbide Head and Hardened Steel Collar

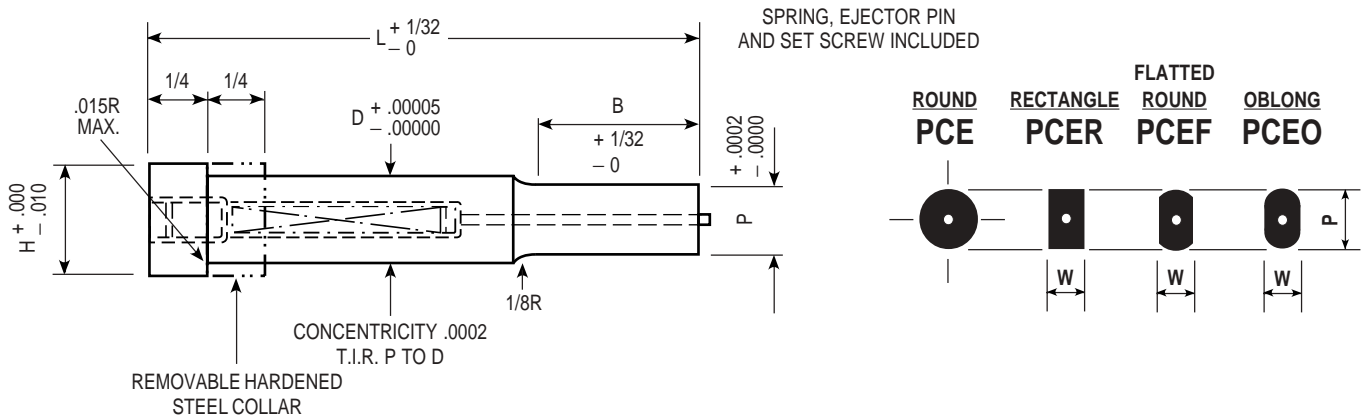

CATALOG NUMBER	D DIAMETER	P POINT DIAMETER	B POINT LENGTH	H HEAD DIAMETER	L = LENGTH									
					2	2 1/4	2 1/2	2 3/4	3	3 1/4	3 1/2	3 3/4	4	
1PCE-18	.1875	.093 - .1259	3/4"	.296	•	•	•	•	•	•	•	•	•	•
2PCE-18	.1875	.126 - .1875	7/8"	.296	•	•	•	•	•	•	•	•	•	•
1PCE-25	.250	.093 - .1259	3/4"	.340	•	•	•	•	•	•	•	•	•	•
2PCE-25	.250	.126 - .250	7/8"	.340	•	•	•	•	•	•	•	•	•	•
1PCE-31	.3125	.125 - .2499	7/8"	.400	•	•	•	•	•	•	•	•	•	•
2PCE-31	.3125	.250 - .3125	7/8"	.400	•	•	•	•	•	•	•	•	•	•
1PCE-37	.375	.187 - .3139	7/8"	.460	•	•	•	•	•	•	•	•	•	•
2PCE-37	.375	.314 - .375	7/8"	.460	•	•	•	•	•	•	•	•	•	•
1PCE-43	.4375	.314 - .3749	7/8"	.562	•	•	•	•	•	•	•	•	•	•
2PCE-43	.4375	.375 - .4375	7/8"	.562	•	•	•	•	•	•	•	•	•	•
1PCE-50	.500	.375 - .4379	7/8"	.625	•	•	•	•	•	•	•	•	•	•
2PCE-50	.500	.438 - .500	7/8"	.625	•	•	•	•	•	•	•	•	•	•
1PCE-62	.625	.438 - .5299	7/8"	.750	•	•	•	•	•	•	•	•	•	•
2PCE-62	.625	.530 - .625	7/8"	.750	•	•	•	•	•	•	•	•	•	•

NOTE: ANY DIMENSION OTHER THAN THOSE SHOWN QUOTED ON REQUEST

All outside corners to be sharp unless otherwise specified by customer.

## WHEN ORDERING SPECIFY:

Quantity	Catalog Number	L	P
3	1PCE-31	2 1/2"	.1265"

Quantity	Catalog Number	L	Point Dimensions
12	1PCER-31	3"	W = .1875" P = .2500"



# Carbide Step-A-Head® Punches

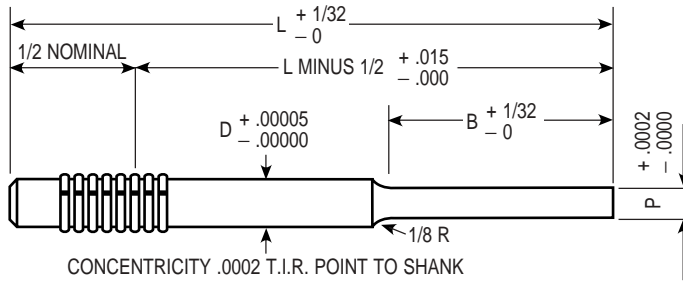

●  
ROUND

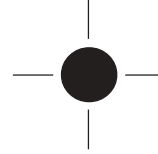

CATALOG NUMBER	D BODY DIAMETER	P POINT DIAMETER	B POINT LENGTH	L = LENGTH										
				2	2¼	2½	2¾	3	3¼	3½	3¾	4		
1PG-18	.1875	.0310 - .0609	5/16"	•	•	•	•	•	•	•	•	•	•	•
2PG-18	.1875	.0610 - .1875	3/4"	•	•	•	•	•	•	•	•	•	•	•
1PG-25	.250	.060 - .1259	3/4"	•	•	•	•	•	•	•	•	•	•	•
2PG-25	.250	.126 - .250	7/8"	•	•	•	•	•	•	•	•	•	•	•
1PG-31	.3125	.125 - .2499	7/8"	•	•	•	•	•	•	•	•	•	•	•
2PG-31	.3125	.250 - .3125	7/8"	•	•	•	•	•	•	•	•	•	•	•
1PG-37	.375	.187 - .3139	7/8"	•	•	•	•	•	•	•	•	•	•	•
2PG-37	.375	.314 - .375	7/8"	•	•	•	•	•	•	•	•	•	•	•
1PG-43	.4375	.314 - .3749	7/8"	•	•	•	•	•	•	•	•	•	•	•
2PG-43	.4375	.375 - .4375	7/8"	•	•	•	•	•	•	•	•	•	•	•



WHEN ORDERING SPECIFY:

Quantity	Catalog Number	L	P
3	2PG-25	3"	.140"

NOTE: ANY DIMENSION OTHER THAN THOSE SHOWN QUOTED ON REQUEST

# Carbide Heavy Duty Step-A-Head® Punches

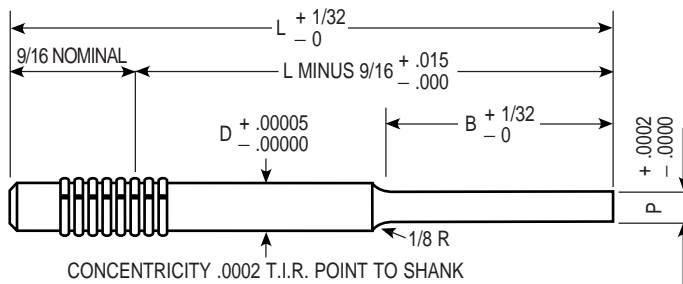

●  
ROUND

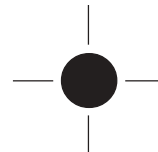

CATALOG NUMBER	D BODY DIAMETER	P POINT DIAMETER	B POINT LENGTH	L = LENGTH										
				2	2¼	2½	2¾	3	3¼	3½	3¾	4		
1PGH-50	.500	.375 - .4379	7/8"	•	•	•	•	•	•	•	•	•	•	•
2PGH-50	.500	.438 - .500	7/8"	•	•	•	•	•	•	•	•	•	•	•
1PGH-62	.625	.438 - .5299	7/8"	•	•	•	•	•	•	•	•	•	•	•
2PGH-62	.625	.530 - .625	7/8"	•	•	•	•	•	•	•	•	•	•	•
1PGH-75	.750	.530 - .6299	7/8"	•	•	•	•	•	•	•	•	•	•	•
2PGH-75	.750	.630 - .750	7/8"	•	•	•	•	•	•	•	•	•	•	•

WHEN ORDERING SPECIFY:

Quantity	Catalog Number	L	P
2	1PGH-75	3"	.612"

NOTE: ANY DIMENSION OTHER THAN THOSE SHOWN QUOTED ON REQUEST

# Carbide Punches, Ball Retainer Type – Light Duty

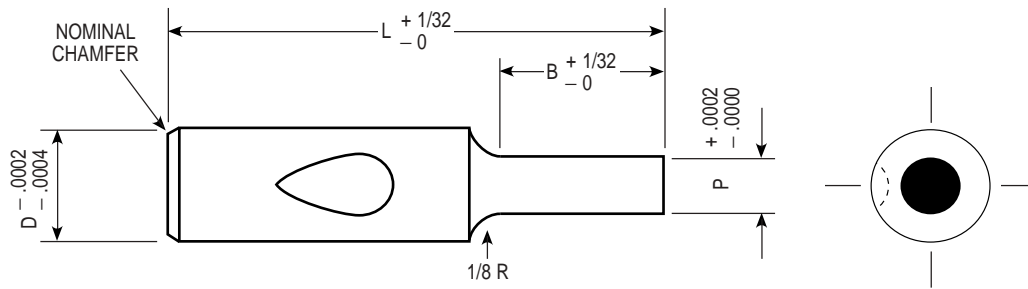

CONCENTRICITY .0002" T.I.R. POINT TO SHANK

CATALOG NUMBER	D DIAMETER	P POINT DIAMETER	B POINT LENGTH	L = LENGTH						
				2	2¼	2½	2¾	3	3¼	3½
1PB-25	.250	.060 - .090	3/8"	•	•	•	•	•	•	•
2PB-25	.250	.0901 - .125	3/8"	•	•	•	•	•	•	•
3PB-25	.250	.1251 - .250	3/8"	•	•	•	•	•	•	•
1PB-37	.375	.187 - .250	1/2"	•	•	•	•	•	•	•
2PB-37	.375	.2501 - .313	1/2"	•	•	•	•	•	•	•
3PB-37	.375	.3131 - .375	1/2"	•	•	•	•	•	•	•
1PB-50	.500	.250 - .325	5/8"	•	•	•	•	•	•	•
2PB-50	.500	.3251 - .400	5/8"	•	•	•	•	•	•	•
3PB-50	.500	.4001 - .500	5/8"	•	•	•	•	•	•	•

NOTE: ANY DIMENSION OTHER THAN THOSE SHOWN QUOTED ON REQUEST

#### WHEN ORDERING SPECIFY:

Quantity	Catalog Number	L	P
3	1PB-50	2½"	.2630"

*Note: Heavy duty available.*



# Carbide Die Inserts with Full Length Taper

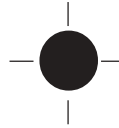
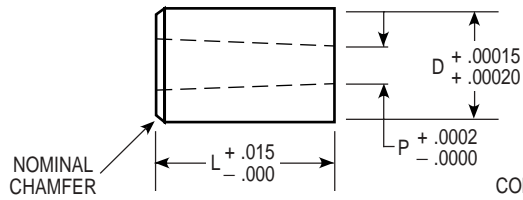

**ROUND**

CONCENTRICITY O.D. AND I.D., .0002" T.I.R.  
TAPER IN "P," .0025" PER INCH PER SIDE

CATALOG NUMBER	D BODY DIAMETER	P INSIDE DIAMETER	L = LENGTH	
			1	1 1/4
1DT-18	.1875	.030 - .0519	•	•
2DT-18	.1875	.052 - .0749	•	•
3DT-18	.1875	.075 - .0969	•	•
1DT-25A	.250	.030 - .0519	•	•
1DT-25	.250	.052 - .0749	•	•
2DT-25	.250	.075 - .0969	•	•
3DT-25	.250	.097 - .1199	•	•
4DT-25	.250	.120 - .156	•	•
1DT-31	.3125	.030 - .0519	•	•
2DT-31	.3125	.052 - .0749	•	•
3DT-31	.3125	.075 - .0969	•	•
4DT-31	.3125	.097 - .1199	•	•
5DT-31	.3125	.120 - .206	•	•
1DT-37	.375	.030 - .0519	•	•
2DT-37	.375	.052 - .0749	•	•
3DT-37	.375	.075 - .0969	•	•
4DT-37	.375	.097 - .1199	•	•
5DT-37	.375	.120 - .206	•	•



WHEN ORDERING SPECIFY:

Quantity	Catalog Number	L	P
3	5DT-37	1"	.1620"

NOTE: ANY DIMENSION OTHER THAN THOSE SHOWN QUOTED ON REQUEST

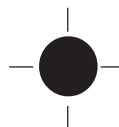
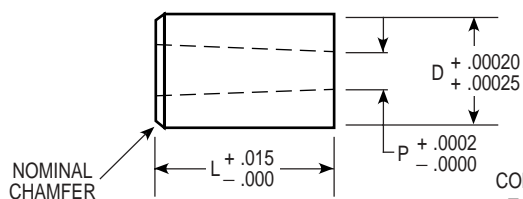

**ROUND**

CONCENTRICITY O.D. AND I.D., .0002" T.I.R.  
TAPER IN "P," .0025" PER INCH PER SIDE

CATALOG NUMBER	D BODY DIAMETER	P INSIDE DIAMETER	L = LENGTH	
			1	1 1/4
1DT-43	.4375	.156 - .2009	•	•
2DT-43	.4375	.201 - .248	•	•
3DT-43	.4375	.2481 - .336	•	•
1DT-50	.500	.156 - .2009	•	•
2DT-50	.500	.201 - .248	•	•
3DT-50	.500	.2481 - .336	•	•
1DT-62	.625	.260 - .396	•	•
1DT-75	.750	.3125 - .526	•	•
1DT-87	.875	.375 - .590	•	•
1DT-100	1.000	.375 - .690	•	•

WHEN ORDERING SPECIFY:

Quantity	Catalog Number	L	P
2	3DT-50	1 1/4"	.2520"

NOTE: ANY DIMENSION OTHER THAN THOSE SHOWN QUOTED ON REQUEST

# Carbide Die Inserts with Full Length Taper and Machinable Steel Sleeve Head

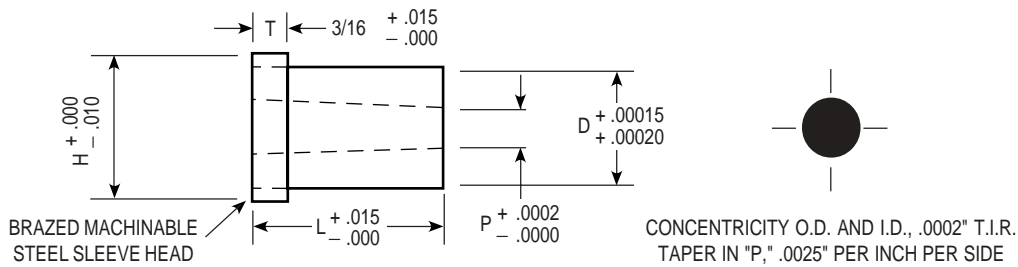

CATALOG NUMBER	D BODY DIAMETER	P INSIDE DIAMETER	H HEAD DIAMETER	L = LENGTH	
				1	1/4
1DTS-18	.1875	.030 - .0519	.296	•	•
2DTS-18	.1875	.052 - .0749	.296	•	•
3DTS-18	.1875	.075 - .0969	.296	•	•
1DTS-25A	.250	.030 - .0519	.340	•	•
1DTS-25	.250	.052 - .0749	.340	•	•
2DTS-25	.250	.075 - .0969	.340	•	•
3DTS-25	.250	.097 - .1199	.340	•	•
4DTS-25	.250	.120 - .156	.340	•	•
1DTS-31	.3125	.030 - .0519	.400	•	•
2DTS-31	.3125	.052 - .0749	.400	•	•
3DTS-31	.3125	.075 - .0969	.400	•	•
4DTS-31	.3125	.097 - .1199	.400	•	•
5DTS-31	.3125	.120 - .206	.400	•	•
1DTS-37	.375	.030 - .0519	.460	•	•
2DTS-37	.375	.052 - .0749	.460	•	•
3DTS-37	.375	.075 - .0969	.460	•	•
4DTS-37	.375	.097 - .1199	.460	•	•
5DTS-37	.375	.120 - .206	.460	•	•



WHEN ORDERING SPECIFY:

Quantity	Catalog Number	L	P
6	3DTS-37	1/4"	.0960"

NOTE: ANY DIMENSION OTHER THAN THOSE SHOWN QUOTED ON REQUEST

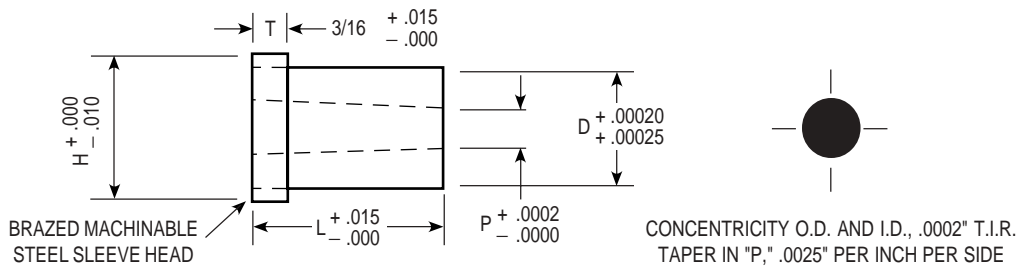

CATALOG NUMBER	D BODY DIAMETER	P INSIDE DIAMETER	H HEAD DIAMETER	L = LENGTH	
				1	1/4
1DTS-43	.4375	.156 - .2009	.562	•	•
2DTS-43	.4375	.201 - .248	.562	•	•
3DTS-43	.4375	.2481 - .336	.562	•	•
1DTS-50	.500	.156 - .2009	.625	•	•
2DTS-50	.500	.201 - .248	.625	•	•
3DTS-50	.500	.2481 - .336	.625	•	•
1DTS-62	.625	.260 - .396	.750	•	•
1DTS-75	.750	.3125 - .526	.875	•	•
1DTS-87	.875	.375 - .590	1.000	•	•
1DTS-100	1.000	.375 - .690	1.125	•	•

WHEN ORDERING SPECIFY:

Quantity	Catalog Number	L	P
6	3DTS-50	1/4"	.2960"

NOTE: ANY DIMENSION OTHER THAN THOSE SHOWN QUOTED ON REQUEST

# Carbide Die Inserts with Counterbore

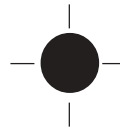
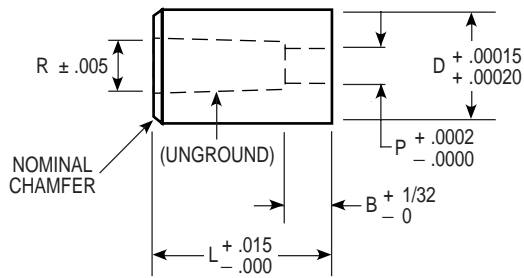

CONCENTRICITY O.D. AND I.D., .0002" T.I.R.  
TAPER IN "P," .0025" PER INCH PER SIDE

CATALOG NUMBER	D BODY DIAMETER	P INSIDE DIAMETER	R RELIEF DIAMETER	B LAND	L = LENGTH	
					1	1¼
1DC-18A	.1875	.052 - .0619	.080	1/8"	•	•
1DC-18B	.1875	.062 - .070	.090	1/8"	•	•
2DC-18A	.1875	.0701 - .077	.100	1/8"	•	•
2DC-18B	.1875	.0771 - .087	.108	3/16"	•	•
3DC-18A	.1875	.0871 - .092	.114	3/16"	•	•
1DC-25	.250	.052 - .0619	.080	1/8"	•	•
1DC-25A	.250	.062 - .070	.090	1/8"	•	•
1DC-25B	.250	.0701 - .077	.100	1/8"	•	•
2DC-25A	.250	.0771 - .087	.108	3/16"	•	•
2DC-25B	.250	.0871 - .092	.114	3/16"	•	•
3DC-25A	.250	.0921 - .108	.125	3/16"	•	•
3DC-25B	.250	.1081 - .124	.144	3/16"	•	•
4DC-25	.250	.1241 - .140	.159	1/4"	•	•
1DC-31A	.3125	.062 - .070	.090	1/8"	•	•
1DC-31B	.3125	.0701 - .077	.100	1/8"	•	•
2DC-31A	.3125	.0771 - .087	.108	3/16"	•	•
2DC-31B	.3125	.0871 - .092	.114	3/16"	•	•
3DC-31A	.3125	.0921 - .108	.125	3/16"	•	•
3DC-31B	.3125	.1081 - .124	.144	3/16"	•	•
4DC-31	.3125	.1241 - .140	.159	1/4"	•	•
5DC-31	.3125	.1401 - .180	.209	1/4"	•	•
6DC-31	.3125	.1801 - .195	.219	1/4"	•	•
1DC-37A	.375	.062 - .070	.090	1/8"	•	•
1DC-37B	.375	.0701 - .077	.100	1/8"	•	•
2DC-37A	.375	.0771 - .087	.108	3/16"	•	•
2DC-37B	.375	.0871 - .092	.114	3/16"	•	•
3DC-37A	.375	.0921 - .108	.125	3/16"	•	•
3DC-37B	.375	.1081 - .124	.144	3/16"	•	•
4DC-37	.375	.1241 - .140	.159	1/4"	•	•
5DC-37	.375	.1401 - .180	.209	1/4"	•	•
6DC-37	.375	.1801 - .195	.219	1/4"	•	•



NOTE: ANY DIMENSION OTHER THAN THOSE SHOWN QUOTED ON REQUEST

### WHEN ORDERING SPECIFY:

Quantity	Catalog Number	L	P
6	4DC-31	1"	.1250"

# Carbide Die Inserts with Counterbore

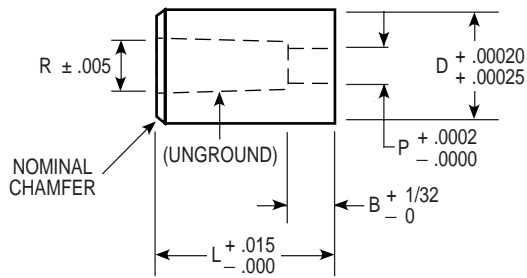

CONCENTRICITY O.D. AND I.D., .0002" T.I.R.  
TAPER IN "P," .0025" PER INCH PER SIDE

CATALOG NUMBER	D BODY DIAMETER	P INSIDE DIAMETER	R RELIEF DIAMETER	B LAND	L = LENGTH	
					1	1¼
1DC-43	.4375	.156 - .200	.219	1/4"	•	•
2DC-43	.4375	.2001 - .248	.269	3/8"	•	•
3DC-43	.4375	.2481 - .300	.319	3/8"	•	•
1DC-50A	.500	.156 - .200	.219	1/4"	•	•
2DC-50	.500	.2001 - .248	.269	3/8"	•	•
3DC-50	.500	.2481 - .300	.319	3/8"	•	•
1DC-62A	.625	.260 - .310	.399	3/8"	•	•
2DC-62	.625	.3101 - .375	.399	3/8"	•	•
3DC-62	.625	.3751 - UP	.469	3/8"	•	•
1DC-75	.750	.3125 - .510	P + .02	3/8"	•	•
1DC-87	.875	.375 - .515	P + .02	3/8"	•	•
1DC-100	1.000	.375 - .675	P + .02	3/8"	•	•

NOTE: ANY DIMENSION OTHER THAN THOSE SHOWN QUOTED ON REQUEST

### WHEN ORDERING SPECIFY:

Quantity	Catalog Number	L	P
6	1DC-50A	1¼"	.1830"

# Carbide Die Inserts with Counterbore and Machinable Steel Sleeve Head

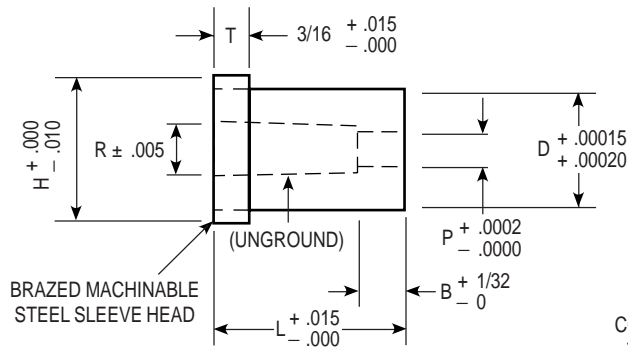

CONCENTRICITY O.D. AND I.D., .0002" T.I.R.  
TAPER IN "P," .0025" PER INCH PER SIDE

CATALOG NUMBER	D BODY DIAMETER	P INSIDE DIAMETER	R RELIEF DIAMETER	B LAND	H HEAD DIAMETER	L = LENGTH	
						1	1/4
1DCS-18A	.1875	.052 - .0619	.080	1/8"	.296	•	•
1DCS-18B	.1875	.062 - .070	.090	1/8"	.296	•	•
2DCS-18A	.1875	.0701 - .077	.100	1/8"	.296	•	•
2DCS-18B	.1875	.0771 - .087	.108	3/16"	.296	•	•
3DCS-18A	.1875	.0871 - .092	.114	3/16"	.296	•	•
1DCS-25	.250	.052 - .0619	.080	1/8"	.340	•	•
1DCS-25A	.250	.062 - .070	.090	1/8"	.340	•	•
1DCS-25B	.250	.0701 - .077	.100	1/8"	.340	•	•
2DCS-25A	.250	.0771 - .087	.108	3/16"	.340	•	•
2DCS-25B	.250	.0871 - .092	.114	3/16"	.340	•	•
3DCS-25A	.250	.0921 - .108	.125	3/16"	.340	•	•
3DCS-25B	.250	.1081 - .124	.144	3/16"	.340	•	•
4DCS-25	.250	.1241 - .140	.159	1/4"	.340	•	•
1DCS-31A	.3125	.062 - .070	.090	1/8"	.400	•	•
1DCS-31B	.3125	.0701 - .077	.100	1/8"	.400	•	•
2DCS-31A	.3125	.0771 - .087	.108	3/16"	.400	•	•
2DCS-31B	.3125	.0871 - .092	.114	3/16"	.400	•	•
3DCS-31A	.3125	.0921 - .108	.125	3/16"	.400	•	•
3DCS-31B	.3125	.1081 - .124	.144	3/16"	.400	•	•
4DCS-31	.3125	.1241 - .140	.159	1/4"	.400	•	•
5DCS-31	.3125	.1401 - .180	.209	1/4"	.400	•	•
6DCS-31	.3125	.1801 - .195	.219	1/4"	.400	•	•
1DCS-37A	.375	.062 - .070	.090	1/8"	.460	•	•
1DCS-37B	.375	.0701 - .077	.100	1/8"	.460	•	•
2DCS-37A	.375	.0771 - .087	.108	3/16"	.460	•	•
2DCS-37B	.375	.0871 - .092	.114	3/16"	.460	•	•
3DCS-37A	.375	.0921 - .108	.125	3/16"	.460	•	•
3DCS-37B	.375	.1081 - .124	.144	3/16"	.460	•	•
4DCS-37	.375	.1241 - .140	.159	1/4"	.460	•	•
5DCS-37	.375	.1401 - .180	.209	1/4"	.460	•	•
6DCS-37	.375	.1801 - .195	.219	1/4"	.460	•	•



NOTE: ANY DIMENSION OTHER THAN THOSE SHOWN QUOTED ON REQUEST

## WHEN ORDERING SPECIFY:

Quantity	Catalog Number	L	P
6	3DCS-31A	1"	.1000"

# Carbide Die Inserts with Counterbore and Machinable Steel Sleeve Head

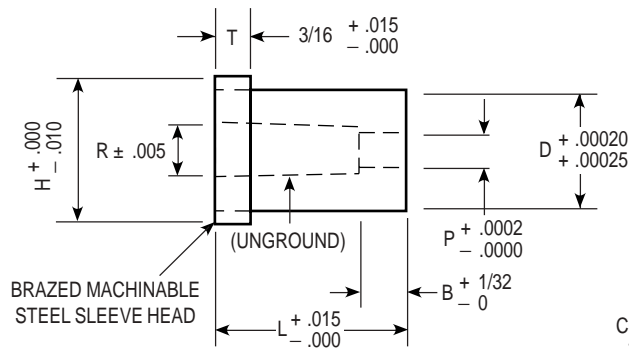

**ROUND**

CONCENTRICITY O.D. AND I.D., .0002" T.I.R.  
TAPER IN "P," .0025" PER INCH PER SIDE

CATALOG NUMBER	D BODY DIAMETER	P INSIDE DIAMETER	R RELIEF DIAMETER	B LAND	H HEAD DIAMETER	L = LENGTH	
						1	1¼
1DCS-43	.4375	.156 - .200	.219	1/4"	.562	•	•
2DCS-43	.4375	.2001 - .248	.269	3/8"	.562	•	•
3DCS-43	.4375	.2481 - .300	.319	3/8"	.562	•	•
1DCS-50A	.500	.156 - .200	.219	1/4"	.625	•	•
2DCS-50	.500	.2001 - .248	.269	3/8"	.625	•	•
3DCS-50	.500	.2481 - .300	.319	3/8"	.625	•	•
1DCS-62A	.625	.260 - .310	.399	3/8"	.750	•	•
2DCS-62	.625	.3101 - .375	.399	3/8"	.750	•	•
3DCS-62	.625	.3751 - UP	.469	3/8"	.750	•	•
1DCS-75	.750	.3125 - .510	P + .02	3/8"	.875	•	•
1DCS-87	.875	.375 - .515	P + .02	3/8"	1.000	•	•
1DCS-100	1.000	.375 - .675	P + .02	3/8"	1.125	•	•

NOTE: ANY DIMENSION OTHER THAN THOSE SHOWN QUOTED ON REQUEST

## WHEN ORDERING SPECIFY:

Quantity	Catalog Number	L	P
6	3DCS-50	1"	.2500"

# Carbide Die Inserts, Half Rounds

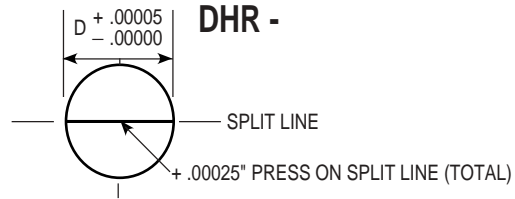
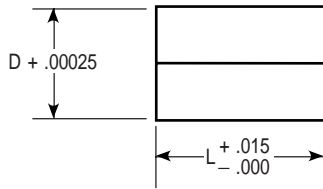

## WHEN ORDERING SPECIFY:

CATALOG NUMBER	D BODY DIAMETER	L = LENGTH	
		1"	1 1/4"
1DHR-25	.250	•	•
1DHR-31	.3125	•	•
1DHR-37	.375	•	•
1DHR-43	.4375	•	•
1DHR-50	.500	•	•
1DHR-62	.625	•	•
1DHR-75	.750	•	•

Quantity	Catalog Number	L
8	1DHR-37	1 1/4"

The press fit across the split is slightly larger than normal to prevent separation during operation.

NOTE: ANY DIMENSION OTHER THAN THOSE SHOWN QUOTED ON REQUEST

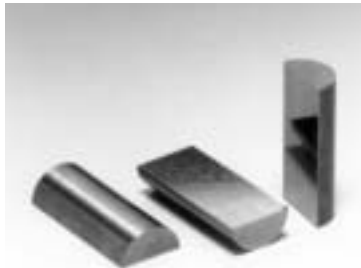

Please specify locating devices by the following designations:

DS = Dowel Slot = .125 Dia.

F1 = Single Flat  $\left(\frac{D}{2} - .0625\right)$

F2 = Double Flat  $\left(\frac{D}{2} - .0625\right)$

All locating devices will be parallel to the longest dimension. (See page ii.)  
Special locations or devices will be furnished if fully dimensioned print is provided.

## DHR -

## DHRR -

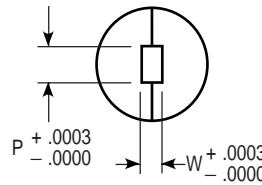

## RECTANGLE (Including Square)

INTERNAL TAPER  $0^\circ 9'$  PER SIDE\*  
CORNER RADIUS = .005"  
CONCENTRICITY O.D. AND I.D. .0003" T.I.R.

## WHEN ORDERING SPECIFY:

Quantity	Catalog Number	L	Hole Size		Locating Device
			W	P	
26	1DHRR-37	1 1/4"	.080	.160	F1

## DHRF -

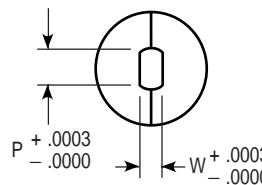

## FLATTED ROUND

INTERNAL TAPER  $0^\circ 9'$  PER SIDE\*  
CORNER RADIUS = .005"  
CONCENTRICITY O.D. AND I.D. .0003" T.I.R.

## WHEN ORDERING SPECIFY:

Quantity	Catalog Number	L	Hole Size		Locating Device
			W	P	
18	1DHRF-37	1 1/4"	.080	.160	F1

## DHRO -

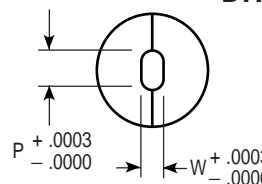

## OBLONG

INTERNAL TAPER  $0^\circ 9'$  PER SIDE\*  
CONCENTRICITY O.D. AND I.D. .0003" T.I.R.

## WHEN ORDERING SPECIFY:

Quantity	Catalog Number	L	Hole Size		Locating Device
			W	P	
18	1DHRO-37	1 1/4"	.080	.160	F1

# Carbide Die Inserts, Wire EDM Blanks With Starter Hole

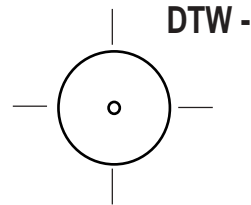
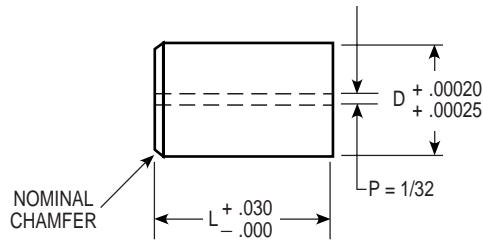

CATALOG NUMBER	D BODY DIAMETER	L = LENGTH	
		1"	1 1/4"
1DTW-18	.1875	•	•
1DTW-25	.250	•	•
1DTW-31	.3125	•	•
1DTW-37	.375	•	•
1DTW-43	.4375	•	•
1DTW-50	.500	•	•
1DTW-62	.625	•	•
1DTW-75	.750	•	•
1DTW-87	.875	•	•
1DTW-100	1.000	•	•

NOTE: ANY DIMENSION OTHER THAN THOSE SHOWN QUOTED ON REQUEST

## WHEN ORDERING SPECIFY:

Quantity	Catalog Number	L
4	1DTW-31	1"

## BRAZED MACHINABLE STEEL SLEEVE HEAD AVAILABLE



Please specify locating devices by the following designations:

DS = Dowel Slot = .125 Dia.

F1 = Single Flat  $\left(\frac{D}{2} - .0625\right)$

F2 = Double Flat  $\left(\frac{D}{2} - .0625\right)$

All locating devices will be parallel to the longest dimension. (See page ii.)  
Special locations or devices will be furnished if fully dimensioned print is provided.

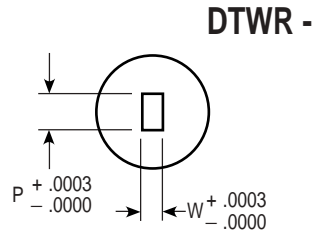

## RECTANGLE (Including Square)

INTERNAL TAPER  $0^{\circ} 9'$  PER SIDE\*  
CORNER RADIUS = .007"  
CONCENTRICITY O.D. AND I.D. .0003" T.I.R.

## WHEN ORDERING SPECIFY:

Quantity	Catalog Number	L	Hole Size		Locating Device
			W	P	
7	1DTWR-87	1"	.130	.175	F1

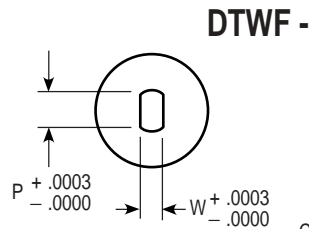

## FLATTED ROUND

INTERNAL TAPER  $0^{\circ} 9'$  PER SIDE\*  
CORNER RADIUS = .007"  
CONCENTRICITY O.D. AND I.D. .0003" T.I.R.

## WHEN ORDERING SPECIFY:

Quantity	Catalog Number	L	Hole Size		Locating Device
			W	P	
5	1DTWF-87	1"	.205	.400	F1

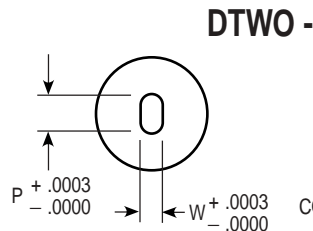

## OBLONG

INTERNAL TAPER  $0^{\circ} 9'$  PER SIDE\*  
CONCENTRICITY O.D. AND I.D. .0003" T.I.R.

## WHEN ORDERING SPECIFY:

Quantity	Catalog Number	L	Hole Size		Locating Device
			W	P	
5	1DTWO-62	1 1/4"	.123	.300	F1

# Carbide Drill Jig Bushings Slip Renewable Type "CSR"

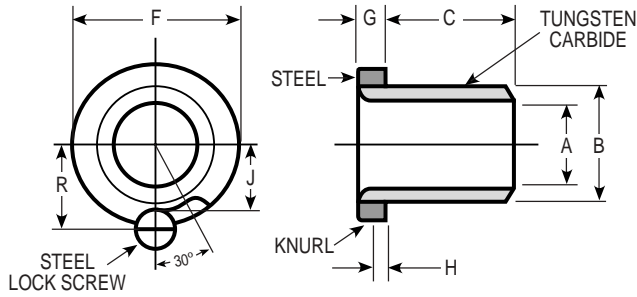

STANDARD DRILL SIZE A	ACTUAL O.D. B	LENGTH UNDER HEAD C	SYMBOL FOR O.D. FINISH GROUND	HEAD SIZE					LOCK SCREW TO USE
				F	G	H	J	R	
.0630 to .0890	.3125	5/16"	CSR-20-5	35/64"	3/8"	1/8"	11/64"	1/2"	1A
	.3123	1/2"	CSR-20-8						
	.3125	3/4"	CSR-20-12						
	.3123	1"	CSR-20-16						
.0935 to .1562	.3125	5/16"	CSR-20-5	35/64"	3/8"	1/8"	11/64"	1/2"	1A
	.3123	1/2"	CSR-20-8						
	.5000	3/4"	CSR-20-12						
	.4998	1"	CSR-20-16						
.1570 to .1875	.5000	5/16"	CSR-32-5	51/64"	7/16"	1/8"	19/64"	5/8"	1A
	.4998	1/2"	CSR-32-8						
	.5000	3/4"	CSR-32-12						
	.4998	1"	CSR-32-16						
.1890 to .3125	.5000	1-3/8"	CSR-32-22	51/64"	7/16"	1/8"	19/64"	5/8"	1A
	.4998	1"	CSR-32-16						
.3160 to .5000	.7500	5/16"	CSR-32-5	1-3/64"	7/16"	1/8"	27/64"	3/4"	1A
	.7498	1/2"	CSR-32-8						
	1.0000	3/4"	CSR-32-12						
	.9998	1"	CSR-32-16						
.5156 to .7500	1.0000	1-3/8"	CSR-48-8	1-27/64"	7/16"	3/16"	19/32"	59/64"	2A
	.9998	1-3/4"	CSR-48-12						
	1.3750	1"	CSR-48-16						
	1.3747	1-3/8"	CSR-48-22						
.7656 to 1.0000	1.3750	3/4"	CSR-64-8	1-51/64"	7/16"	3/16"	25/32"	1-7/64"	2A
	1.3747	1"	CSR-64-12						
	1.7500	1-3/8"	CSR-64-16						
	1.7497	1-3/4"	CSR-64-22						
1.0156 to 1.3750	1.7500	2-1/8"	CSR-88-12	2-19/64"	5/8"	3/16"	1"	1-25/64"	3A
	1.7497	2-1/2"	CSR-88-16						
	2.2500	3"	CSR-88-22						
	2.2496	1"	CSR-88-28						
1.3906 to 1.7500	2.2500	1-3/8"	CSR-88-34	2-51/64"	5/8"	3/16"	1-1/4"	1-41/64"	3A
	2.2496	1-3/4"	CSR-88-40						
	2.2496	2-1/8"	CSR-112-16						
	2.2496	2-1/2"	CSR-112-22						
	2.2496	3"	CSR-112-28						
	2.2496	1"	CSR-112-34						
	2.2496	1-3/8"	CSR-112-40						
	2.2496	1-3/4"	CSR-112-48						

NOTE: ANY DIMENSION OTHER THAN THOSE SHOWN QUOTED ON REQUEST

### Hole Tolerances:

Up to 1/4" +.0001 to +.0004  
 Up to 3/4" +.0001 to +.0005  
 Up to 1-1/2" +.0002 to +.0006  
 Over 1-1/2" +.0003 to +.0007

Bodies of Carbide Bushings are solid Tungsten Carbide; Type "CH", "CSR" and "CFR" have Steel Heads. Concentricity held to within .0003.

All Removable Slip Fit Standard A.S.A. Carbide Bushings are ground on the O.D. with a Slip Fit clearance to fit into a Standard A.S.A. Steel Liner Bushing.

# Carbide Drill Jig Bushings Fixed Renewable Type "CFR"

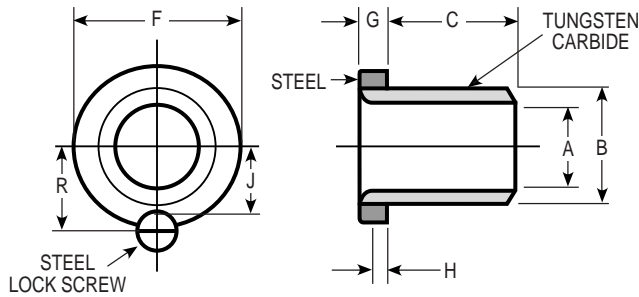

STANDARD DRILL SIZE A	ACTUAL O.D. B	LENGTH UNDER HEAD C	SYMBOL FOR O.D. FINISH GROUND	HEAD SIZE					LOCK SCREW TO USE
				F	G	H	J	R	
.0630 to .0890	.3125	5/16"	CFR-20-5	35/64"	1/4"	1/8"	11/64"	1/2"	1A
	.3123	1/2"	CFR-20-8						
	.3125	3/4"	CFR-20-12						
	.3123	1"	CFR-20-16						
.0935 to .1562	.3125	5/16"	CFR-20-5	35/64"	1/4"	1/8"	11/64"	1/2"	1A
	.3123	1/2"	CFR-20-8						
	.5000	3/4"	CFR-20-12						
	.4998	1"	CFR-20-16						
.1570 to .1875	.5000	5/16"	CFR-32-5	51/64"	1/4"	1/8"	19/64"	5/8"	1A
	.4998	1/2"	CFR-32-8						
	.5000	3/4"	CFR-32-12						
	.4998	1"	CFR-32-16						
.1890 to .3125	.5000	1-3/8"	CFR-32-22	51/64"	1/4"	1/8"	19/64"	5/8"	1A
	.4998	1"	CFR-32-16						
	.7500	5/16"	CFR-32-5	1-3/64"	1/4"	1/8"	27/64"	3/4"	1A
	7498	1/2"	CFR-32-8						
.3160 to .5000	.7500	3/4"	CFR-48-8						
	7498	1"	CFR-48-12						
	1.0000	1-3/8"	CFR-48-16						
	.9998	1-3/4"	CFR-48-22						
.5156 to .7500	1.0000	1/2"	CFR-64-8	1-27/64"	3/8"	3/16"	19/32"	59/64"	2A
	.9998	3/4"	CFR-64-12						
	1.3750	1"	CFR-64-16						
	1.3747	1-3/8"	CFR-64-22						
.7656 to 1.0000	1.3750	1-3/4"	CFR-88-12	1-51/64"	3/8"	3/16"	25/32"	1-7/64"	2A
	1.3747	1"	CFR-88-16						
	1.7500	1-3/8"	CFR-88-22						
	1.7497	1-3/4"	CFR-88-28						
1.0156 to 1.3750	1.7500	2-1/8"	CFR-88-34	2-19/64"	3/8"	3/16"	1"	1-25/64"	3A
	1.7497	2-1/2"	CFR-88-40						
	2.2500	3"	CFR-112-16						
	2.2496	1"	CFR-112-22						
1.3906 to 1.7500	2.2500	1-3/8"	CFR-112-28	2-51/64"	3/8"	3/16"	1-1/4"	1-41/64"	3A
	2.2496	1-3/4"	CFR-112-34						
	2.2496	2-1/8"	CFR-112-40						
	2.2496	2-1/2"	CFR-112-48						
	2.2500	1"	CFR-144-16						
	2.2496	1-3/8"	CFR-144-22						
	2.2496	1-3/4"	CFR-144-28						
	2.2496	2-1/8"	CFR-144-34						
	2.2496	2-1/2"	CFR-144-40						
	2.2496	3"	CFR-144-48						

NOTE: ANY DIMENSION OTHER THAN THOSE SHOWN QUOTED ON REQUEST

### Hole Tolerances:

Up to 1/4" +.0001 to +.0004  
 Up to 3/4" +.0001 to +.0005  
 Up to 1-1/2" +.0002 to +.0006  
 Over 1-1/2" +.0003 to +.0007

Bodies of Carbide Bushings are solid Tungsten Carbide; Type "CH", "CSR" and "CFR" have Steel Heads. Concentricity held to within .0003.

All Removable Slip Fit Standard A.S.A. Carbide Bushings are ground on the O.D. with a Slip Fit clearance to fit into a Standard A.S.A. Steel Liner Bushing.

# Carbide Drill Jig Bushings

## Press Fit Type "CP" and "CH"

HEADLESS PRESS FIT TYPE "CP"

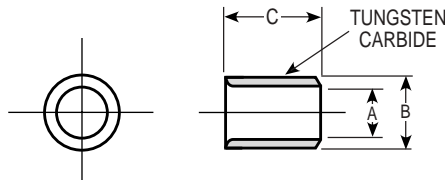

HEAD PRESS FIT TYPE "CH"

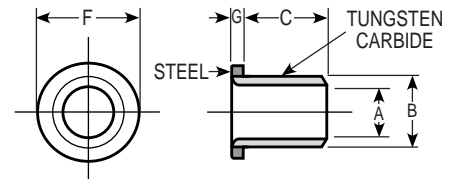

STANDARD DRILL SIZE A	ACTUAL O.D. B	LENGTH C	SYMBOL FOR O.D. FINISH GROUND
.0135 to .0200	.1578	1/4"	CP-10-4
	.1575	5/16"	CP-10-5
.0210 to .0312	.1578	1/4"	CP-10-4
	.1575	5/16"	CP-10-5
.0320 to .0469	.1578	1/4"	CP-10-4
	.1575	5/16"	CP-10-5
.0630 to .0995	.2046	1/4"	CP-13-4
	.2043	5/16"	CP-13-5
.1015 to .1360	.2516	1/4"	CP-16-4
	.2513	5/16"	CP-16-5
.1405 to .1875	.3141	5/16"	CP-20-5
	.3138	1/2"	CP-20-8
.1890 to .2500	.4078	1/2"	CP-26-5
	.4075	3/4"	CP-26-8
.2570 to .3125	.5017	3/4"	CP-32-5
	.5014	1"	CP-32-8
.3160 to .4219	.6267	1"	CP-40-8
	.6264	1-3/8"	CP-40-12
.4375 to .5000	.7518	3/4"	CP-48-8
	.7515	1"	CP-48-12
.5156 to .6250	.8768	1"	CP-56-12
	.8765	1-3/8"	CP-56-16
.6406 to .7500	1.0018	1"	CP-64-8
	1.0015	1-3/8"	CP-64-12
.7656 to 1.0000	1.3772	1"	CP-88-12
	1.3768	1-3/8"	CP-88-16
1.0156 to 1.3750	1.7523	1"	CP-112-16
	1.7519	1-3/8"	CP-112-22
1.3906 to 1.7500	2.2525	1"	CP-144-16
	2.2521	1-3/8"	CP-144-22

STANDARD DRILL SIZE A	ACTUAL O.D. B	LENGTH C	SYMBOL FOR O.D. FINISH GROUND
.4375 to .5000	.7518 .7515	1/2"	CP-48-8
		3/4"	CP-48-12
		1"	CP-48-16
.5156 to .6250	.8768 .8765	3/4"	CP-56-12
		1"	CP-56-16
		1-3/8"	CP-56-22
.6406 to .7500	1.0018 1.0015	1/2"	CP-64-8
		3/4"	CP-64-12
		1"	CP-64-16
.7656 to 1.0000	1.3772 1.3768	3/4"	CP-88-12
		1"	CP-88-16
		1-3/8"	CP-88-22
1.0156 to 1.3750	1.7523 1.7519	1"	CP-112-16
		1-3/8"	CP-112-22
		1-3/4"	CP-112-28
1.3906 to 1.7500	2.2525 2.2521	2-1/8"	CP-144-34
		2-1/2"	CP-144-40
		3"	CP-144-48

STANDARD DRILL SIZE A	ACTUAL O.D. B	LENGTH C	SYMBOL FOR O.D. FINISH GROUND	TYPE "CH" ONLY	
				F	G
.0630 to .0995	.2046 .2043	5/16"	CH-13-5	19/64"	3/32"
		1/2"	CH-13-8		
.1015 to .1360	.2516 .2513	5/16"	CH-16-5	23/64"	3/32"
		1/2"	CH-16-8		
.1405 to .1875	.3141 .3138	5/16"	CH-20-5	27/64"	1/8"
		1/2"	CH-20-8		
.1890 to .2500	.4078 .4075	3/4"	CH-20-12	27/64"	1/8"
		1"	CH-20-16		
.2570 to .3125	.5017 .5014	5/16"	CH-26-5	1/2"	5/32"
		1/2"	CH-26-8		
.3160 to .4219	.6267 .6264	3/4"	CH-26-12	1/2"	5/32"
		1"	CH-26-16		
.4375 to .5000	.7518 .7515	5/16"	CH-32-5	39/64"	7/32"
		1/2"	CH-32-8		
.5156 to .6250	.8768 .8765	3/4"	CH-32-12	39/64"	7/32"
		1"	CH-32-16		
.6406 to .7500	1.0018 1.0015	1"	CH-32-22	39/64"	7/32"
		1-3/8"	CH-32-28		
.7656 to 1.0000	1.3772 1.3768	1/2"	CH-40-8	51/64"	7/32"
		3/4"	CH-40-12		
1.0156 to 1.3750	1.7523 1.7519	1"	CH-40-16	51/64"	7/32"
		1-3/8"	CH-40-22		
1.3906 to 1.7500	2.2525 2.2521	1/2"	CH-48-8	59/64"	7/32"
		3/4"	CH-48-12		
.5156 to .6250	.8768 .8765	1"	CH-48-16	59/64"	7/32"
		1-3/8"	CH-48-22		
.6406 to .7500	1.0018 1.0015	3/4"	CH-56-12	1-7/64"	1/4"
		1"	CH-56-16		
.7656 to 1.0000	1.3772 1.3768	1-3/8"	CH-56-22	1-7/64"	1/4"
		1-3/4"	CH-56-28		
1.0156 to 1.3750	1.7523 1.7519	1"	CH-64-8	1-15/64"	5/16"
		1-3/8"	CH-64-12		
1.3906 to 1.7500	2.2525 2.2521	3/4"	CH-64-16	1-15/64"	5/16"
		1"	CH-64-22		
.5156 to .6250	.8768 .8765	1"	CH-64-28	1-15/64"	5/16"
		1-3/8"	CH-64-34		
.6406 to .7500	1.0018 1.0015	1-3/8"	CH-88-12	1-39/64"	3/8"
		1"	CH-88-16		
.7656 to 1.0000	1.3772 1.3768	1-3/4"	CH-88-22	1-39/64"	3/8"
		1"	CH-88-28		
1.0156 to 1.3750	1.7523 1.7519	2-1/8"	CH-88-34	1-39/64"	3/8"
		2-1/2"	CH-88-40		
1.3906 to 1.7500	2.2525 2.2521	1"	CH-112-16	1-63/64"	3/8"
		1-3/8"	CH-112-22		
.5156 to .6250	.8768 .8765	1-3/4"	CH-112-28	1-63/64"	3/8"
		2-1/8"	CH-112-34		
.6406 to .7500	1.0018 1.0015	2-1/2"	CH-112-40	1-63/64"	3/8"
		3"	CH-112-48		
1.0156 to 1.3750	1.7523 1.7519	1"	CH-144-16	2-31/64"	3/8"
		1-3/8"	CH-144-22		
1.3906 to 1.7500	2.2525 2.2521	1-3/4"	CH-144-28	2-31/64"	3/8"
		2-1/8"	CH-144-34		
.5156 to .6250	.8768 .8765	2-1/2"	CH-144-40	2-31/64"	3/8"
		3"	CH-144-48		

NOTE: ANY DIMENSION OTHER THAN THOSE SHOWN QUOTED ON REQUEST

**Hole Tolerances:**

- Up to 1/4" +.0001 to +.0004
- Up to 3/4" +.0001 to +.0005
- Up to 1-1/2" +.0002 to +.0006
- Over 1-1/2" +.0003 to +.0007

Bodies of Carbide Bushings are solid Tungsten Carbide; Type "CH", "CSR" and "CFR" have Steel Heads. Concentricity held to within .0003.

All Removable Slip Fit Standard A.S.A. Carbide Bushings are ground on the O.D. with a Slip Fit clearance to fit into a Standard A.S.A. Steel Liner Bushing.

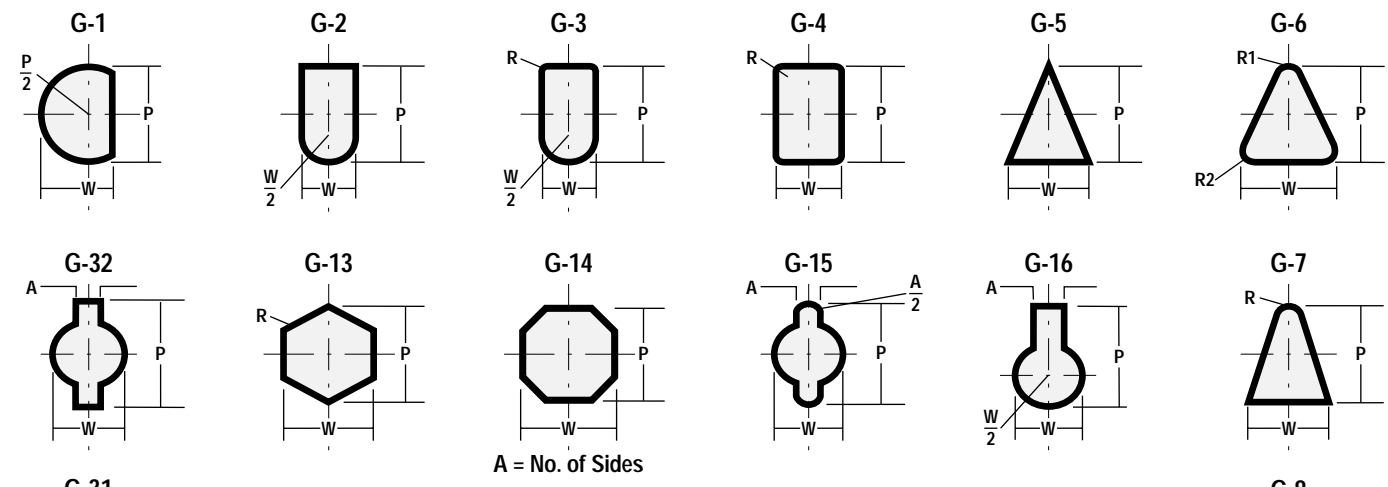

A = No. of Sides

***Special Shapes***

Our customers have requirements for punches and inserts with special shapes or configurations. We have manufactured literally hundreds of these special shaped components for companies all over the world. Those shown on this page represent only a random sampling. We'd like to quote on your next "special." For any shape not listed, send us your fully dimensioned print and we'll send you a quotation.

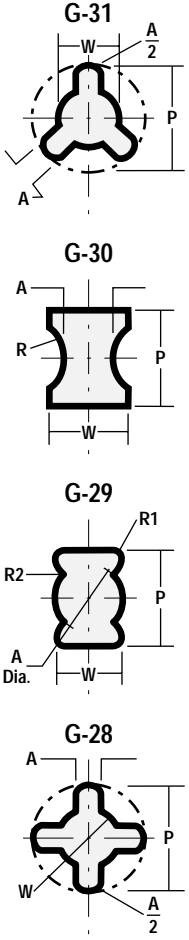

A = No. of Sides

A = No. of Teeth

# Locating Devices

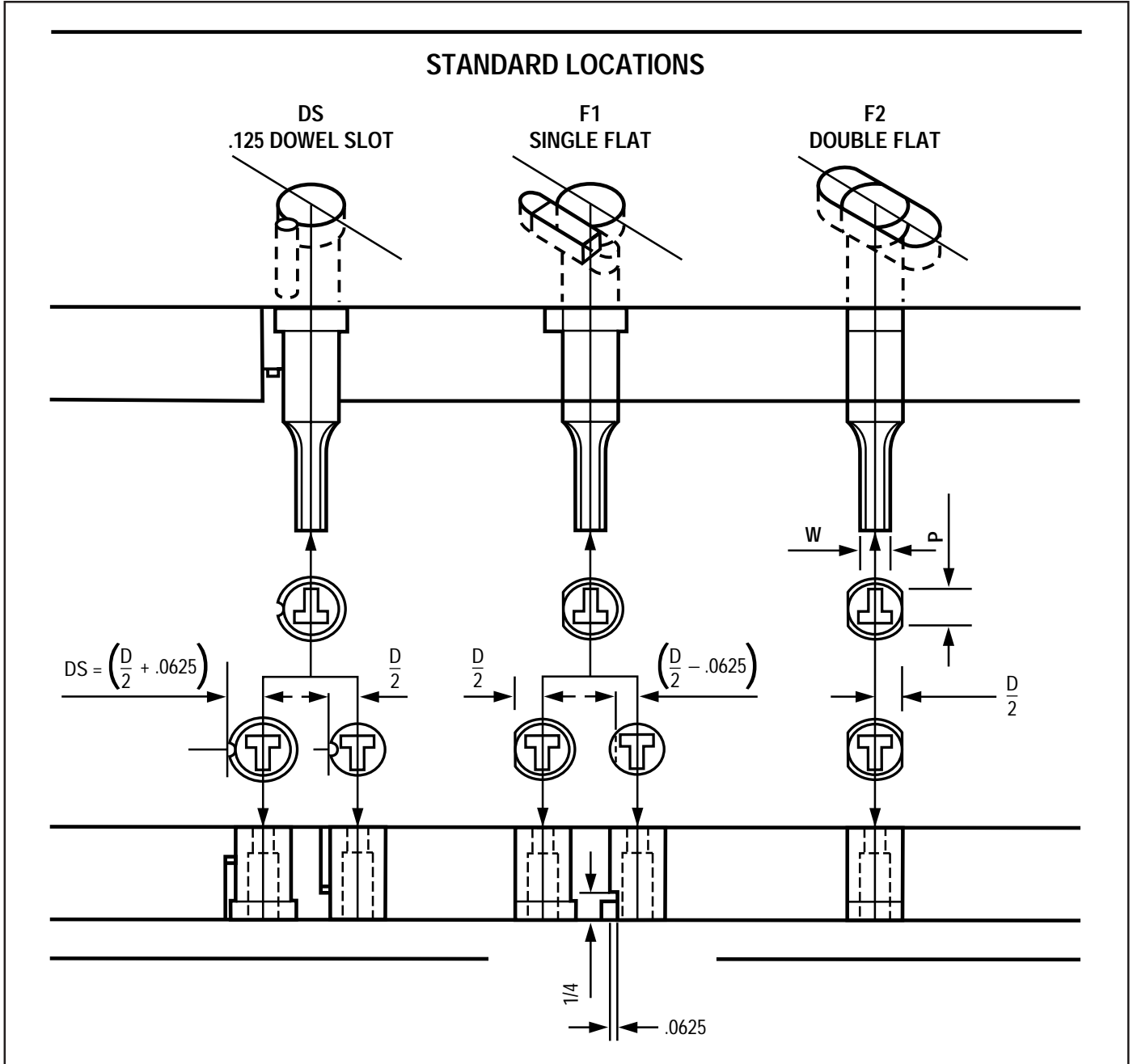

## STANDARD LOCATIONS

Standard dowel and key locations are located parallel to the longest dimension ("P") for positive alignment.

## HOW TO ORDER

Use code — DS, F1, or F2 after item ordered.

Please specify locating devices by the following designations:

DS = Dowel Slot = .125 Dia.

F1 = Single Flat  $\left(\frac{D}{2} - .0625\right)$

F2 = Double Flat  $\left(\frac{D}{2} - .0625\right)$

All locating devices will be parallel to the longest dimension.

Special locations or devices will be furnished if fully dimensioned print is provided.

# Oberg Precision Tooling

---

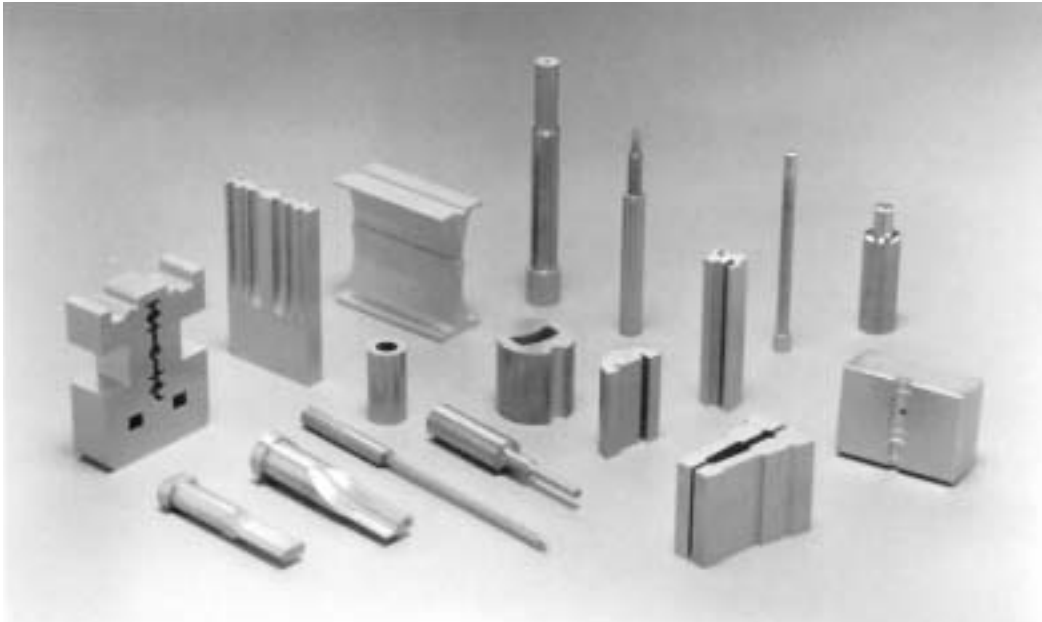

Oberg Industries manufactures carbide die components specifically to your print or drawing, regardless of shape or size. In many instances your special die components can be either precision ground or manufactured utilizing traveling wire electrical discharge machining (EDM).

Since 1948 Oberg Industries has been recognized as the world's leading manufacturer of precision carbide stamping die components, tooling and carbide wear parts. We specialize in the design and build of precision dies to make both flat and formed parts, especially those producing one or multiple parts with each press stroke.

With the finest manufacturing facilities and equipment, operated by the best trained craftsmen available, we've committed ourselves to maintaining our industry leadership position well into the 21st Century.